

Chem 111**9:05a section****Evening Exam #3**

This exam is composed of **25** questions. Go initially through the exam and answer the questions you can answer *quickly*. Then go back and try the ones that are more challenging to you and/or that require calculations.

As discussed on the course syllabus, honesty and integrity are absolute essentials for this class. In fairness to others, dishonest behavior will be dealt with to the full extent of University regulations.

$$E = h\nu = \frac{hc}{\lambda}$$

$$1 \text{ mL} = 1 \text{ cm}^3$$

$$\text{Hz} = \text{s}^{-1}$$

$$h = 6.626 \times 10^{-34} \text{ J s}$$

$$c = 2.998 \times 10^8 \text{ m s}^{-1}$$

$$N = 6.022 \times 10^{23} \text{ mol}^{-1}$$

PERIODIC TABLE OF THE ELEMENTS

1A	2A	3B	4B	5B	6B	7B	8B	8B	8B	1B	2B	3A	4A	5A	6A	7A	8A
1 H 1.008																	2 He 4.003
3 Li 6.939	4 Be 9.012											5 B 10.81	6 C 12.01	7 N 14.01	8 O 16.00	9 F 19.00	10 Ne 20.18
11 Na 22.99	12 Mg 24.31											13 Al 26.98	14 Si 28.09	15 P 30.97	16 S 32.07	17 Cl 35.45	18 Ar 39.95
19 K 39.10	20 Ca 40.08	21 Sc 44.96	22 Ti 47.90	23 V 50.94	24 Cr 52.00	25 Mn 54.94	26 Fe 55.85	27 Co 58.93	28 Ni 58.71	29 Cu 63.55	30 Zn 65.39	31 Ga 69.72	32 Ge 72.61	33 As 74.92	34 Se 78.96	35 Br 79.90	36 Kr 83.80
37 Rb 85.47	38 Sr 87.62	39 Y 88.91	40 Zr 91.22	41 Nb 92.91	42 Mo 95.94	43 Tc (99)	44 Ru 101.1	45 Rh 102.9	46 Pd 106.4	47 Ag 107.9	48 Cd 112.4	49 In 114.8	50 Sn 118.7	51 Sb 121.8	52 Te 127.6	53 I 126.9	54 Xe 131.3
55 Cs 132.9	56 Ba 137.3	57 La 138.9	72 Hf 178.5	73 Ta 181.0	74 W 183.8	75 Re 186.2	76 Os 190.2	77 Ir 192.2	78 Pt 195.1	79 Au 197.0	80 Hg 200.6	81 Tl 204.4	82 Pb 207.2	83 Bi 209.0	84 Po (209)	85 At (210)	86 Rn (222)
87 Fr (223)	88 Ra 226.0	89 Ac 227.0	104 Unq (261)	105 Unp (262)	106 Unh (263)	107 Uns (262)	108 Uno (265)	109 Une (266)									

Solubility Rules for some ionic compounds in water**Soluble Ionic Compounds**

- All sodium (Na^+), potassium (K^+), and ammonium (NH_4^+) salts are SOLUBLE.
- All nitrate (NO_3^-), acetate (CH_3CO_2^-), chlorate (ClO_3^-), and perchlorate (ClO_4^-) salts are SOLUBLE.
- All chloride (Cl^-), bromide (Br^-), and iodide (I^-) salts are SOLUBLE -- EXCEPT those also containing: lead, silver, or mercury (I) (Pb^{2+} , Ag^+ , Hg_2^{2+}) which are NOT soluble.
- All sulfate (SO_4^{2-}) salts are SOLUBLE -- EXCEPT those also containing: calcium, silver, mercury (I), strontium, barium, or lead (Ca^{2+} , Ag^+ , Hg_2^{2+} , Sr^{2+} , Ba^{2+} , Pb^{2+}) which are NOT soluble.

Not Soluble Ionic Compounds

- Hydroxide (OH^-) and oxide (O^{2-}) compounds are NOT SOLUBLE -- EXCEPT those also containing: sodium, potassium, or barium (Na^+ , K^+ , Ba^{2+}) which are soluble.
- Sulfide (S^{2-}) salts are NOT SOLUBLE -- EXCEPT those also containing: sodium, potassium, ammonium, or barium (Na^+ , K^+ , NH_4^+ , Ba^{2+}) which are soluble.
- Carbonate (CO_3^{2-}) and phosphate (PO_4^{3-}) salts are NOT SOLUBLE -- EXCEPT those also containing: sodium, potassium, or ammonium (Na^+ , K^+ , NH_4^+), which are soluble.

- What is the molecular geometry of XeF_4 ?
 - square planar
 - octahedral
 - trigonal bipyramidal
 - square pyramidal
 - none of the above

- XeF_4 is:
 - polar
 - nonpolar
 - can't tell

- What is the molecular geometry of ClF_3 ?
 - square planar
 - octahedral
 - trigonal bipyramidal
 - square pyramidal
 - trigonal planar

- ClF_3 is:
 - polar
 - nonpolar
 - can't tell

- Using the simplified molecular orbital diagram at right, predict the true bond order in CN^+ .
 - single
 - double
 - triple
 - 1.5
 - 2.5

- Using the simplified molecular orbital diagram above, predict the true bond order in O_2^+ .
 - single
 - double
 - triple
 - 1.5
 - 2.5



7. Each carbon in CH_3CH_3 requires which type of orbital hybridization?

- 1) sp^4 2) sp^3 3) sp^2 4) sp
 5) none of the above

8. How many atomic orbitals were used to create each of the resulting hybrid orbitals above?

- 1) 1 2) 2 3) 3 4) 4 5) 5

9. Which of the following molecular orbital representations correctly describes C_2^+ ?

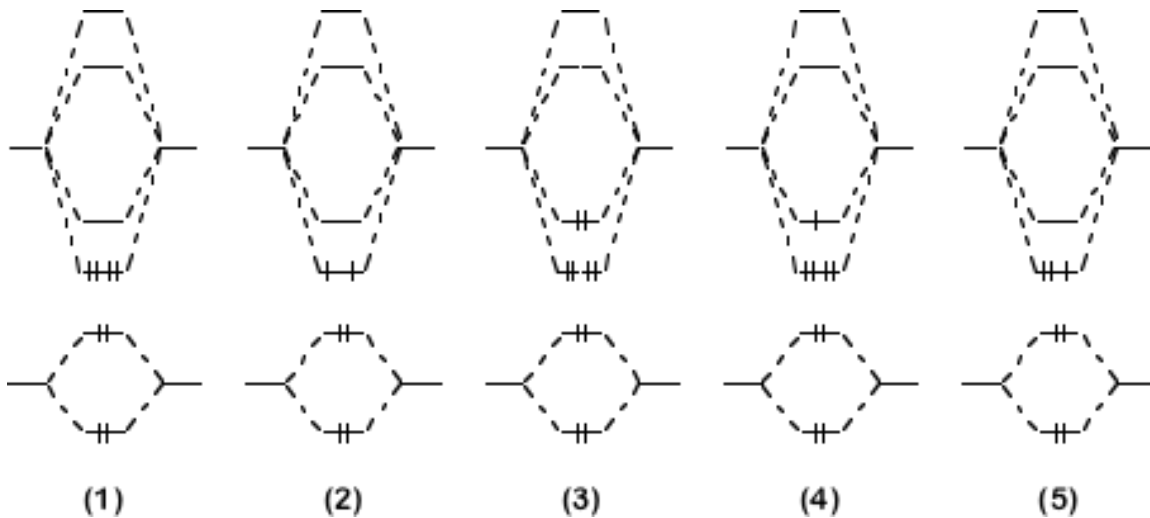

10. For the diatomic molecule XY, the diagram at right depicts:

- 1) one π bonding orbital
- 2) two π bonding orbitals
- 3) one sigma bonding orbital
- 4) two sigma bonding orbitals
- 5) one 2p atomic orbital

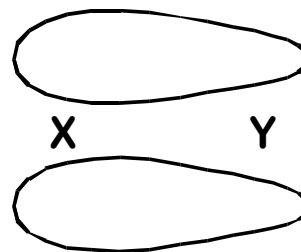

11. In the diatomic molecule XY, above, we can deduce that:

- 1) atom X has a higher electronegativity than atom Y
- 2) atom Y has a higher electronegativity than atom X
- 3) atoms X and Y have the same electronegativity
- 4) we have insufficient data to distinguish the relative electronegativities

12. In the diatomic molecule XY, above the orbital(s) is/are likely derived from:

- 1) one sp hybrid orbital on X and another sp hybrid orbital on Y
- 2) one s atomic orbital on X and another s atomic orbital on Y
- 3) one s atomic orbital on X and a p atomic orbital on Y
- 4) one p atomic orbital on X and an s atomic orbital on Y
- 5) one p atomic orbital on X and another p atomic orbital on Y

13. Mixing $\text{Ba}(\text{NO}_3)_2$ with CaCl_2 in water leads to precipitation of:

- 1) a NO_3^- salt
- 2) a Ca^{2+} salt
- 3) a Cl^- salt
- 4) everything precipitates
- 5) no precipitation

14. Gold can be dissolved from gold-bearing rock by treating the rock with sodium cyanide in the presence of oxygen.

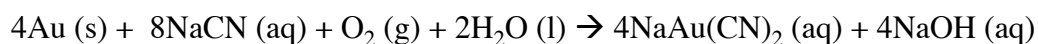

For this reaction, what is the reducing agent?

- 1) Au
- 2) NaCN
- 3) O_2
- 4) H_2O
- 5) H^+

15. Consider the reaction:

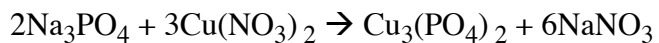

This reaction is best classified as:

- 1) oxidation-reduction 2) precipitation 3) acid-base
4) gas-evolving 5) gas evolving and precipitation

16. Consider the reaction:

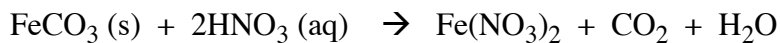

This reaction is best classified as:

- 1) oxidation-reduction 2) precipitation 3) acid-base
4) gas-evolving 5) gas evolving and acid-base

17. CdSe finds many uses in electronics and the computer industry. What is the oxidation number of Cd in CdSe?

- 1) -1 2) 0 3) 1 4) 2 5) 4

18. Alka seltzer is a combination of citric acid, $\text{C}_6\text{H}_8\text{O}_7$, and NaHCO_3^- . They react in your glass to form $\text{C}_6\text{H}_7\text{O}_7^-$, H_2O , and CO_2

What is the oxidation number of C in $\text{C}_6\text{H}_7\text{O}_7^-$?

- 1) +1 2) +2 3) +3 4) +6 5) -6

19. Write the balanced, *net ionic equation* corresponding to the unbalanced equation:

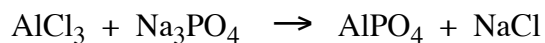

The coefficient in front of Al^{3+} (aq) is:

1) 1 2) 2 3) 3 4) 4

5) 0 (Al^{3+} doesn't occur in the net ionic equation)

20. Which reaction below is a redox reaction?

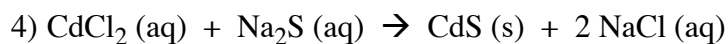
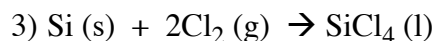
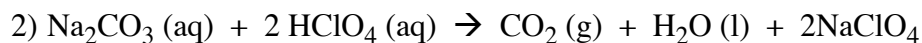
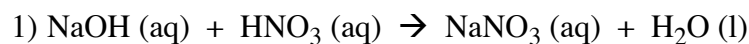

5) None of the above

21. The net ionic equation for the reaction of zinc sulfate and sodium hydroxide is:

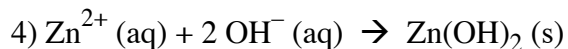
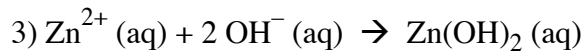
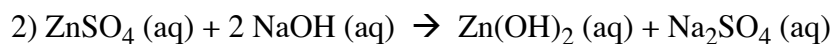
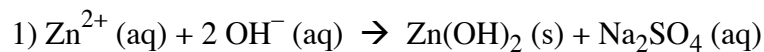

5) No *net* reaction occurs

22. Dissolving BaO in water leads to:

- 1) a resulting acidic solution
- 2) a resulting basic solution
- 3) no change in pH of the solution

23. Which of the following is the strongest acid?

- 1) H_3PO_4 2) H_2CO_3 3) CH_3COOH 4) NH_3 5) HNO_3

24. In benzene, shown at right, there are 3 pi bonding and 3 pi antibonding molecular orbitals. How many carbon 2p orbitals are used in creating these molecular orbitals?

- 1) 1 2) 2 3) 3 4) 6 5) 12

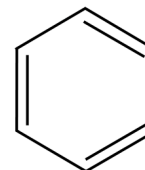

25. The correct designator for this course is:

- 1) Chem 262 2) Chem 111 3) Econ 3.33 4) Sports 01